

# High Pressure Pumps for Demanding Environments

Gardner Denver, founded in 1859, is a leading global provider of high-quality industrial equipment, technologies and services to a broad and diverse customer base through a family of highly recognized brands.



**Gardner**  
**Denver**

# T-300

- Triplex plunger pump.
- High versatility in pressure and flow rate.
- Extremely reliable – Over 50 years in the market and still going strong.
- Stainless steel fluid end construction.
- Low maintenance cost.
- Easy field maintenance.
- High volumetric efficiency for maximum horsepower utilization.
- Manufactured on state-of-the-art machinery.
- Designed and field proven to run continuously at full load.

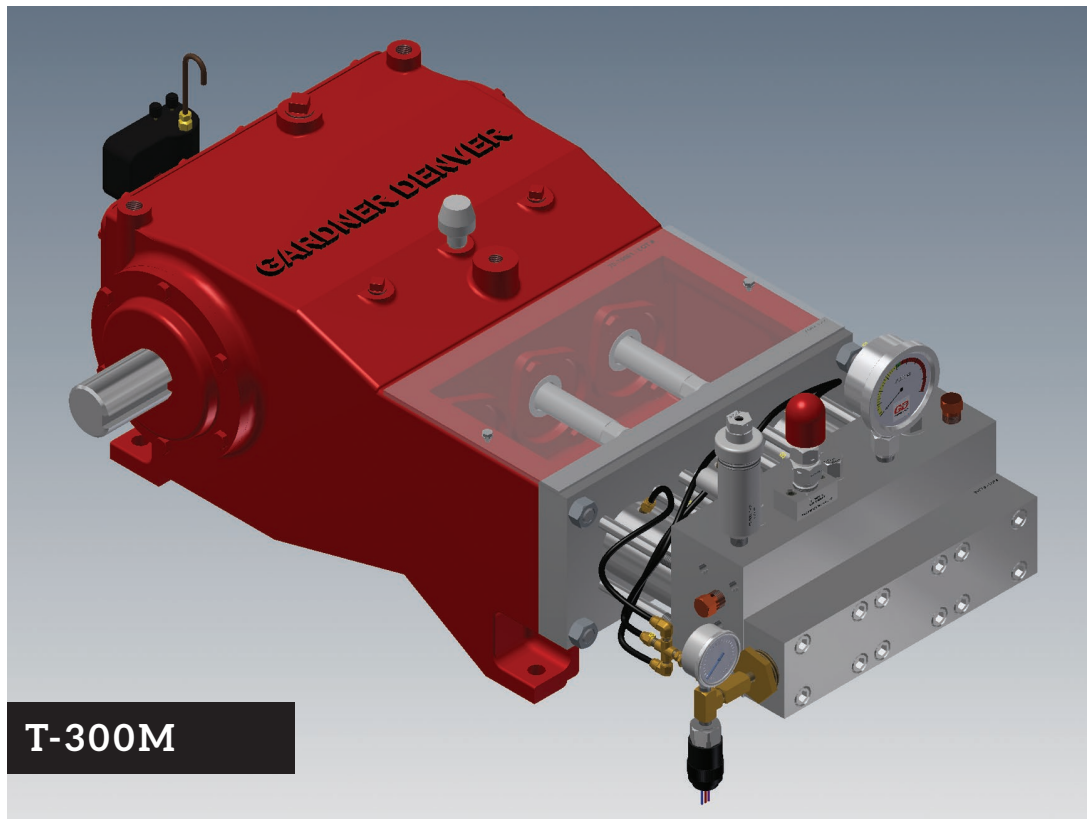

**T-300M** is our best-selling pump. It is well known for its durability, reliability, and low cost of maintenance. The “L” shape fluid end provides easy access to replace both the suction and discharge valves.

**T-300H** is one of Gardner Denver Water Jetting’s most well-known pumps, in service for more than 30 years. The inline fluid end design makes this pump extremely durable and reliable for the toughest applications. Critical pump components are autofrettaged using a proprietary process exclusive only to Gardner Denver.

**T-300UH** is an ultrahigh-pressure pump (UHP) known for industrial cleaning and surface preparation projects. Critical components are autofrettaged to increase the product life.

Pump Model	Max Power HP	Speed (RPM)		Stroke		Plunger Sizes		Max Flow Rate		Max Pressure	
		Min	Max	in	mm	in	mm	GPM	LPM	PSI	Bar
T-300M	100	200	600	3.00	76.2	0.75-1.00	19.0-25.4	18.4	69.6	15000	1034
T-300H	100	200	600	3.00	76.2	0.65-0.75	16.5-19.1	10.3	39.0	20000	1379
T-300UH	100	200	600	3.00	76.2	0.47	12	4.1	15.5	40000	2758

Approximate Dimensions: 41" X 15" X 26" | Approximate Weight: 810 lbs

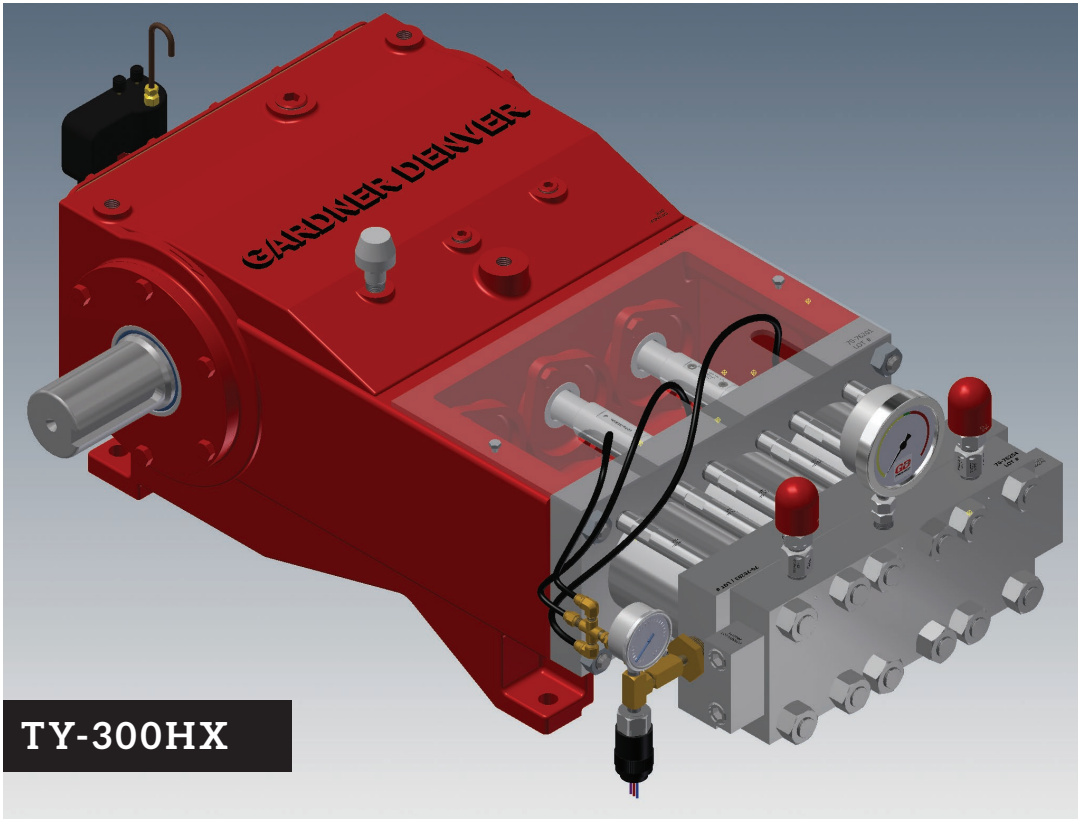

# TY-300

- Triplex plunger pump.
- An upgraded version of T-300 power end with higher load rating.
- High versatility in pressure and flow rate.
- With our patented plunger quick-change, retorquing and unbolting of the fluid end is not required. A complete pressure conversion takes less than 15 minutes.
- Stainless steel fluid construction.
- Low maintenance cost and easy field maintenance.
- High volumetric efficiency for maximum horsepower utilization.
- Manufactured on state-of-the-art machinery.
- Designed and tested rigorously to run continuously at full load.

**TY-300M** is an upgrade of the T-300M, the best-selling pump of Gardner Denver Water Jetting. Upgraded with a power end rated for 150HP, the pump is well known for its durability, reliability, and low cost of maintenance. The "L" shape fluid end provides easy access to replace both suction and discharge valves.

**TY-300H** is an upgrade of the T-300H. In service for more than 30 years, this is one of our best-known pumps. The inline fluid end design makes this pump extremely durable and reliable for the toughest applications.

**TY-300HX** The first 20K PSI pump in the market to introduce a soft seated valve (patent pending). The wide range of pressure applications from 8K PSI to 20K PSI, combined with patented quick plunger change make this pump highly versatile. The pump is specially designed for easy field maintenance, and more resistance to dirty water.

Pump Model	Max Power HP	Speed (RPM)		Stroke		Plunger Sizes		Max Flow Rate		Max Pressure	
		Min	Max	in	mm	in	mm	GPM	LPM	PSI	Bar
TY-300M	150	200	600	3.00	76.2	0.88-1.00	22.4-25.4	18.4	69.6	15000	1034
TY-300H	150	200	600	3.00	76.2	0.75	19.1	10.3	39.0	20000	1379
TY-300HX	150	200	600	3.00	76.2	0.79-1.25	20.0-31.8	28.7	108.6	20000	1379

Approximate Dimensions: 42" X 26" X 16" | Approximate Weight: 940 lbs

# TY-375

- Triplex plunger pump.
- High versatility in pressure and flow rate.
- With our patented plunger quick-change, retorquing and unbolting of the fluid end is not required. A complete pressure conversion takes less than 15 minutes.
- Extremely reliable.
- Stainless steel fluid construction.
- Low maintenance cost
- Easy field maintenance.
- High volumetric efficiency for maximum horsepower utilization.
- Manufactured on state-of-the-art machinery.
- Designed and field proven to run continuously at full load.

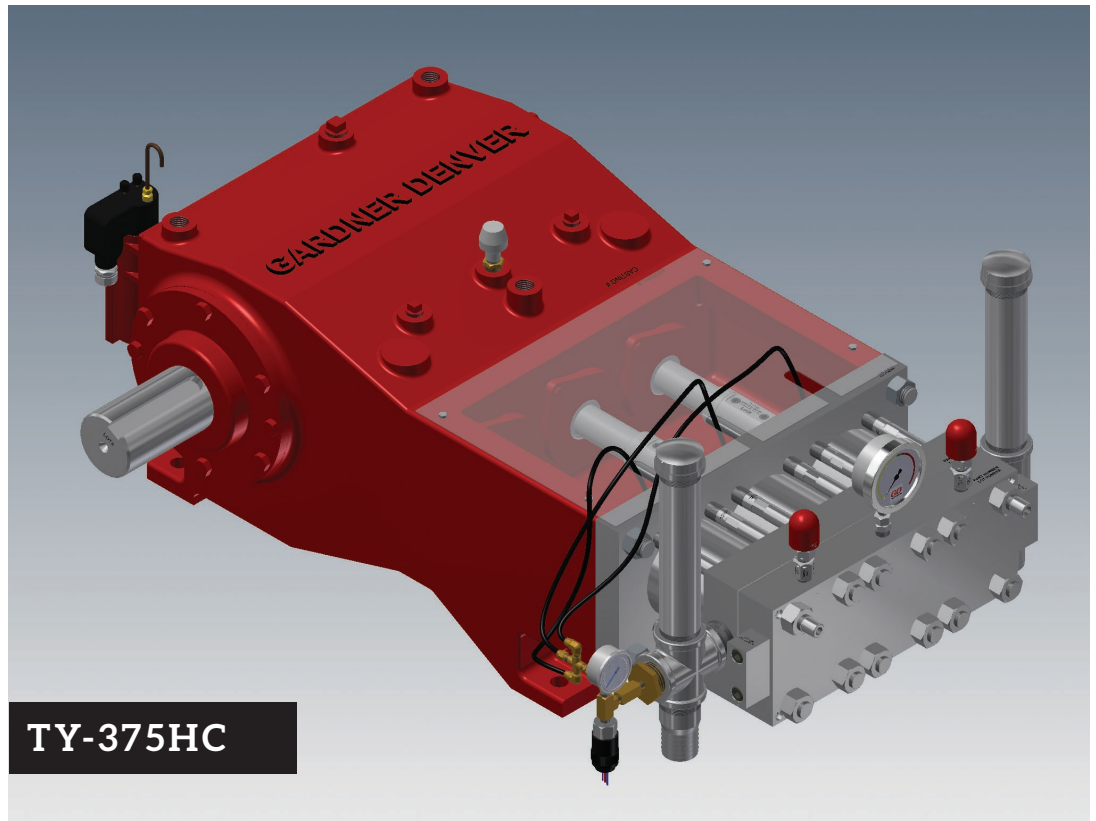

**TY-375S** Specially designed to meet high flow requirements. The sectionalized “L” fluid end design provides flexibility to replace each individual manifold at low cost. Equipped with soft seated valves to increase the life of the valves and provide resistance to dirty water.

**TY-375HC** is a specially designed pump with inline fluid end for high pressure application. The critical components are designed using advance technique Finite Element Analysis (FEA) to improve part life from pressure-cycles. The valve replacement can be done by sliding the discharge manifold on the stud, therefore eliminating the need for heavy lifting. Critical pump components are autofrettaged using a proprietary process exclusive only to Gardner Denver.

**TY-375UH** is an ultrahigh-pressure pump (UHP) known for industrial cleaning and surface preparation projects. It has an inline fluid end which offers high durability and reliability for tough applications and continuous duty. Critical components are autofrettaged to increase product life.

Pump Model	Max Power HP	Speed (RPM)		Stroke		Plunger Sizes		Max Flow Rate		Max Pressure	
		Min	Max	in	mm	in	mm	GPM	LPM	PSI	Bar
TY-375S	300	200	515	3.75	95.25	1.25-1.75	31.8-44.5	58.6	221.8	15000	1034
TY-375HC	300	200	515	3.75	95.25	1.1-1.5	28-38.1	43.0	162.8	20000	1379
TY-375UH	300	200	515	3.75	95.25	0.787	20	11.9	45.0	40000	2758

Approximate Dimensions: 51" X 35" X 20" | Approximate Weight: 1,950 lbs





# TF-450

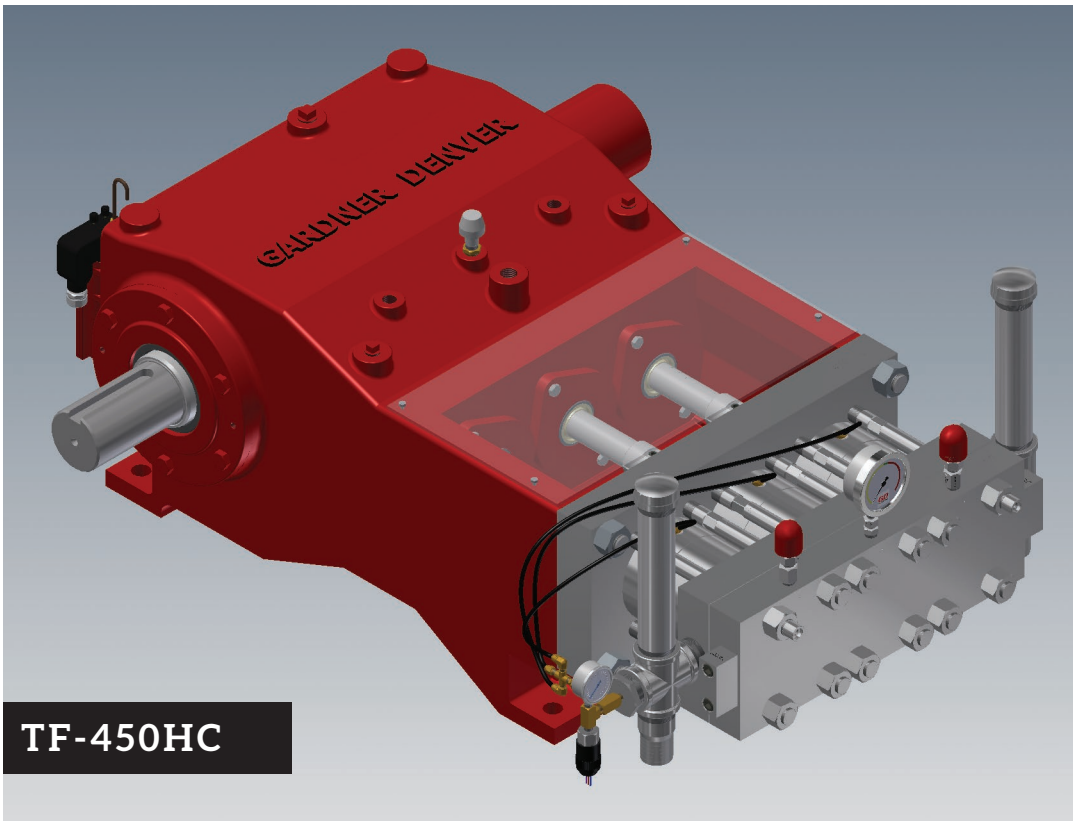

- Triplex plunger pump.
- High versatility in pressure and flow rate.
- With our patented plunger quick-change, retorquing and unbolting of the fluid end is not required. A complete pressure conversion takes less than 15 minutes.
- Extremely reliable.
- Stainless steel fluid construction.
- Low maintenance cost.
- Easy field maintenance.
- High volumetric efficiency for maximum horsepower utilization.
- Manufactured on state-of-the-art machinery.
- Designed and field proven to run continuously at full load.

**TF-450SB** is specially designed to meet high flow requirements. The sectionalized “L” fluid end design provides flexibility to replace each individual manifold at low cost. It is equipped with soft seated valves to increase valve life and provide resistance to dirty water.

**TF-450HC** is a specially designed pump with inline fluid end for high pressure application. The critical components are designed using advance technique Finite Element Analysis (FEA) to improve part life from pressure-cycles. The valve replacement can be done by sliding the discharge manifold on the stud, therefore eliminating the need for heavy lifting.

Pump Model	Max Power HP	Speed (RPM)		Stroke		Plunger Sizes		Max Flow Rate		Max Pressure	
		Min	Max	in	mm	in	mm	GPM	LPM	PSI	Bar
TF-450SB	330	200	515	4.50	114.3	1.50-2.25	38.1-57.2	116.2	439.7	10000	689
TF-450HC	330	200	515	4.50	114.3	1.1-1.5	27.9-38.1	51.6	195.3	20000	1379

Approximate Dimensions: 60" X 48" X 23" | Approximate Weight: 2,600 lbs

# TX-450

- Triplex plunger pump.
- High versatility in pressure and flow rate.
- With our patented plunger quick-change, retorquing and unbolting of the fluid end is not required. A complete pressure conversion takes less than 15 minutes.
- Provision for multi-speed operation. (4.2:1 reduction gear)
- Extremely reliable.
- Stainless steel fluid construction.
- Low maintenance cost
- Easy field maintenance.
- High volumetric efficiency for maximum horsepower utilization.
- Manufactured on state-of-the-art machinery.
- Designed and field proven to run continuously at full load.
- Forced oil lubrication.

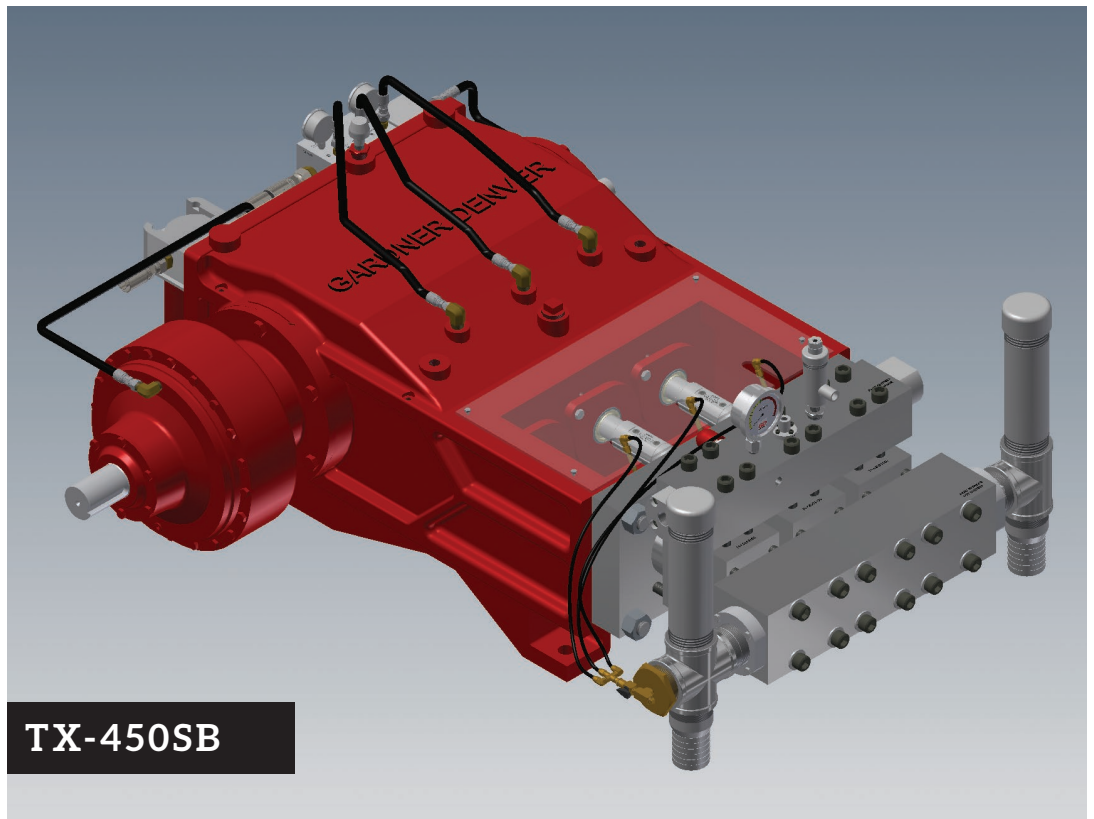

**TX-450SB** is a pump specially designed to meet high flow requirements. The sectionalized "L" fluid end design provides flexibility to replace each individual manifold at low cost. It is equipped with soft seated valves to increase the valve life and provide resistance to dirty water.

**TX-450HC** is a specially designed pump with inline fluid end for high pressure application. The critical components are designed using advance technique Finite Element Analysis (FEA) to improve part life from pressure-cycles. The valve replacement can be done by sliding the discharge manifold on the stud, therefore eliminating the need for heavy lifting.

Pump Model	Max Power	Speed (RPM)		Stroke		Plunger Sizes		Max Flow Rate		Max Pressure	
	HP	Min	Max	in	mm	in	mm	GPM	LPM	PSI	Bar
TX-450SB	450	200	515	4.50	114.3	1.50-2.25	38.1-57.2	116.2	439.7	10000	689
TX-450HC	450	200	515	4.50	114.3	1.1-1.5	27.9-38.1	51.6	195.3	20000	1379

Approximate Dimensions: 63" X 57" X 25" | Approximate Weight: 4,658 lbs

# QF-450

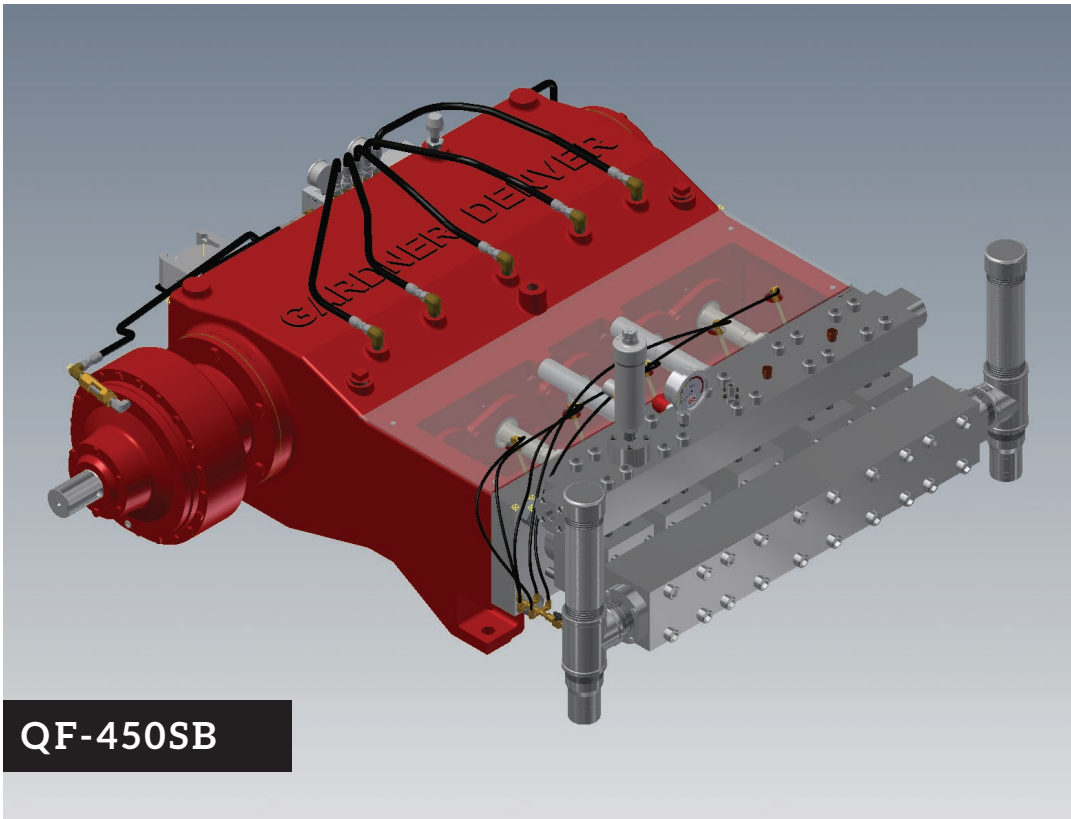

- Quintuplex plunger pump.
- High versatility in pressure and flow rate.
- With our patented plunger quick-change, retorquing and unbolting of the fluid end is not required. A complete pressure conversion takes less than 15 minutes.
- Provision for multi-speed operation.
- Extremely reliable
- Stainless steel fluid construction.
- Low maintenance cost.
- Easy field maintenance.
- High volumetric efficiency for maximum horsepower utilization.
- Manufactured on state-of-the-art machinery.
- Designed and field proven to run continuously at full load.
- Proven quintuplex design preferred in the industry over large triplex design for higher horsepower (500+) applications.
- Forced oil lubrication.

**QF-450SB** is specially designed to meet high flow requirements. The sectionalized “L” fluid end design provides flexibility to replace each individual manifold at low cost. It’s soft seated valves increase valve life and provide resistance to dirty water.

**QF-450HC** is a specially designed pump with inline fluid end for high pressure applications using advance technique Finite Element Analysis (FEA) to improve part life from pressure-cycles. Valve replacement is done by sliding the discharge manifold on the stud, therefore eliminating the need for heavy lifting.

Pump Model	Max Power	Speed (RPM)		Stroke		Plunger Sizes		Max Flow Rate		Max Pressure	
		HP	Min	Max	in	mm	in	mm	GPM	LPM	PSI
QF-450SB	600	200	515	6.00	152.4	1.50-2.25	38.1-57.2	193.6	732.8	10000	689
QF-450HC	600	200	515	6.00	152.4	1.1-1.5	27.9-38.1	86.1	325.9	20000	1379

Approximate Dimensions: 60" X 75" X 21" | Approximate Weight: 5,600 lbs

[www.WaterJetting.com](http://www.WaterJetting.com)  
800-580-5388

**Gardner**  
**Denver**